



**Operation Manual
for the
*mV Computer-Set***

With the purchase of this digital measuring and regulating equipment you have selected a top quality product. It has been specifically designed for aquaristic purposes.

With this unit, you can continuously measure and control the redox-potential of the water in your aquarium.

1. Basics

The redox-potential or oxidation/reduction potential (ORP) is an electrical value which is a parameter for the oxidation and reduction processes in the aquarium.

The redox-potential is of special interest in:

- Assessing the quality of sea water in aquariums. The ideal range is between 300 mV and 400 mV. If needed, the range can be increased by injecting Ozone into the protein skimmer. The higher the value - the higher the percentage of oxidation, the „cleaner“ the water.
- The redox-potential is used in denitrifying filters to check the acidity. The ideal values are between -300 mV and -100 mV.
- -In swimming pools the redox-potential can be used for sterilisation by regulating the amount of chlorine added by maintaining +700 mV.

2. Features

AB Aqua Medic Computers are microprocessor controlled units. They are safe, reliable and meet all the requirements of professional measuring and regulating devices.

The AB Aqua Medic mV-Computer is supplied with a redox probe and standard solution. The ozonizer (not included) can be connected to the female side of the main power plug.

Technical Data	
Micro-processor controlled	
Power requirements	230 V/50 Hz
Output relay-controlled	5 A, 1000 W
Measurement range	-1999 up to +1,999 mV
Adjustment range	-1000 up to +1000 mV
Adjustments	on/off
Hysteresis	adjustable
Adjustment directions adjustable	- upwards, with Ozone filtration mV-value may increase - downwards by adding reducing substances
Redox probe	Plastic shaft (Polysulfon), refillable
Data memory	(power loss protection)

3. Description of the front panel

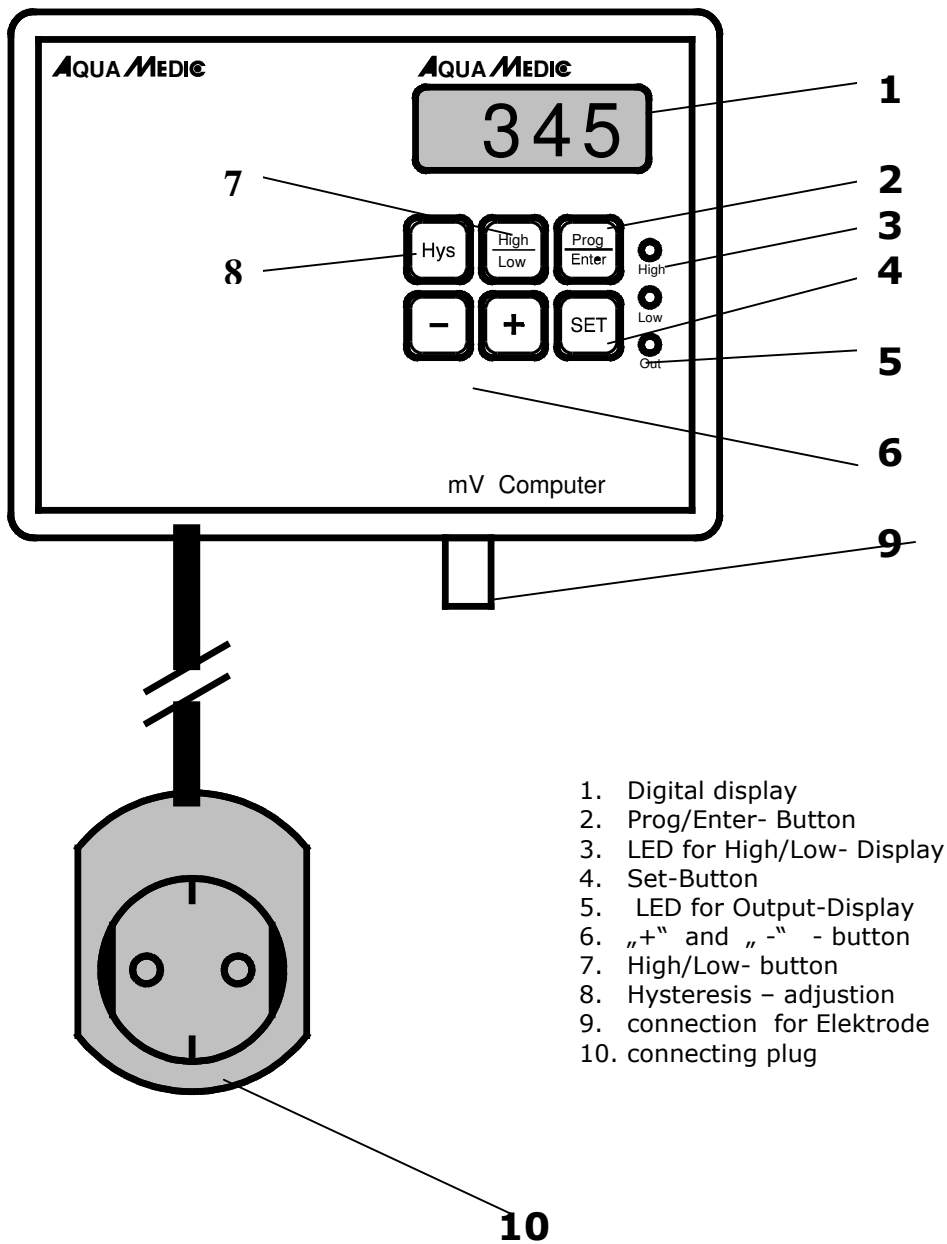

4. Installation

1. Connect to 230 V power source.
2. Connect the mV-probe.

The unit is now ready for programming

5. Adjustment of the control direction

The status of the control direction is shown by the LEDs at the side(3):

Low – an adjusted minimum set point is controlled by the addition of an oxidising agent (e.g. ozone). The direction of control is upwards. This is the standard mode for control of the ORP with Ozone in marine aquariums or for the control of a Nitratoreductor with air or a dosing pump.

High – an adjusted maximum set point is controlled by the addition of a reducing agent. The direction of control is downwards. To change the control mode between High and Low, press the Prog/Enter and the High/Low button simultaneously. The actual mode is shown by the LEDs (3).

6. Adjusting the set point

To adjust the set point, press the Prog/Enter and the SET buttons simultaneously. The adjusted set point is now shown on the display – flashing. It can be changed with the + and – buttons. By pressing the Prog/Enter button again, the set-point is saved. and the display switches back to the actual value.

The hysteresis should be between 5-10 mV. If it is too low, the computer will switch on and off in a very short time. If it is too high, the accuracy will be bad.

7. Sensor calibration

The measurement of the redox-potential is an absolute measurement of voltage. The mV-Computer does not need to be calibrated. Differences may be caused by the electrode. They can be checked with the included standard solution. If the differences are small (10 – 15 MV) the probe can be still used. If the differences are higher, the probe must be cleaned, refilled or replaced.

For continuous measurement of the redox-potential, the probe must be securely placed 5 cm below the surface of the water and the shaft has to be kept dry (we recommend the AB Aqua Medic electrode holder).

The unit is now ready for use. As soon as the redox-potential value falls below or above the desired adjusted value, the unit activates the power plug. This is indicated by the LED out (5)

8. Probe

The AB Aqua Medic probe is specifically designed to determine the redox-potential in fluid based solubles. It can be used in the chemical industry, medical areas and in research laboratories.

8.1 Technical Data

Measurement range:	1,000 - +1,000 mV
Sample temperature:	5-60° C, short-term
Connection:	BNC-plug
Material:	Plastic shaft, Polysulfon, platinum tip

8.2 Measurement/Maintenance

During the measurement the platinum tip must be continuously submerged in the solution. A new probe or one which has been dry for a longer period must lay in water for at least 24 hours.

9. Set up for Control the ORP with an Ozoniser

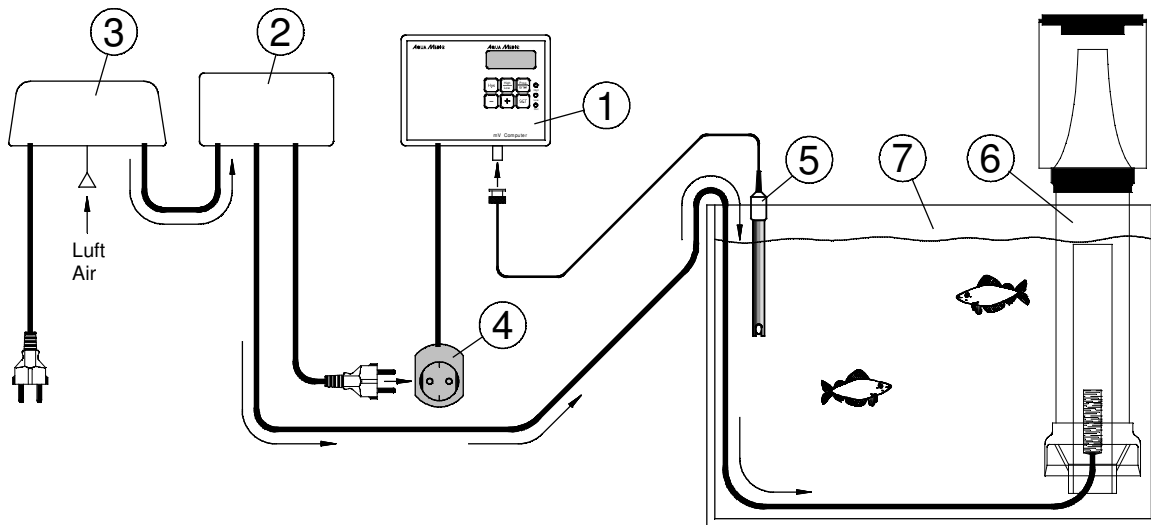

MV- monitoring and control at the aquarium with an Ozoniser.

1. MV computer
2. Ozoniser
3. Membrane air pump
4. Connection plug
5. MV- Elektrode
6. Protein skimmer
7. Aquarium

The pH probe is placed in the aquarium at a dark and well circulated place. The ozoniser is connected to the MV computer (connection plug, 4) and the set point is adjusted as described, e.g. at 400 MV. The air is produced by a membrane air pump, pressed through the ozoniser and directed into the protein skimmer. Here, the small bubbles produce the foam and remove the organics with the aid of the ozone. If the desired ORP value in the aquarium is reached, the ozoniser is switched off. Take care, that all the ozone is used in the protein skimmer and no residual ozone escapes into the air or the water. It can be detected by its strong smell.

10. Malfunctions

- The unit indicates false values --> clean the probe.
- The redox-potential probes have a limited lifespan (1-3 years).

11. Warranty

Should any defect in material or workmanship be found within twentyfour months of the date of purchase AB Aqua Medic GmbH undertakes to repair or, at our option, replace the defective part free of charge – always provided the product has been installed correctly, is used for the purpose that was intended by us, is used in accordance with the operating instructions and is returned to us carriage paid. The warranty term is not applicable on the all consumable products.

Proof of Purchase is required by presentation of an original invoice or receipt indicating the dealer's name, the model number and date of purchase, or a Guarantee Card if appropriate. This warranty may not apply if any model or production number has been altered, deleted or removed, unauthorised persons or organisations have executed repairs, modifications or alterations, or damage is caused by accident, misuse or neglect.

We regret we are unable to accept any liability for any consequential loss.

Please note that the product is not defective under the terms of this warranty where the product, or any of its component parts, was not originally designed and / or manufactured for the market in which it is used.

These statements do not affect your statutory rights as a customer.

If your AB Aqua Medic GmbH product does not appear to be working correctly or appears to be defective please contact your dealer in the first instance.

Before calling your dealer please ensure you have read and understood the operating instructions.

If you have any questions your dealer cannot answer please contact us

Our policy is one of continual technical improvement and we reserve the right to modify and adjust the specification of our products without prior notification

AB AQUA MEDIC GmbH - Gewerbepark 24 - 49143 Bissendorf/Germany

- Technical changes reserved -